



## WARRANTY

**STOP**  
Do not return this product to the store.

**IF YOU NEED HELP OR PARTS, CALL THE COLEMAN® HOTLINE**

**1-800-275-4617**

**HOURS: 10AM-7PM EST Mon-Fri, CLOSED Saturday and Sunday**

**GET HELP FOR:**

MISSING/DAMAGED PARTS • ASSEMBLY • TROUBLESHOOTING  
• WARRANTY ASSISTANCE • PRODUCT INFORMATION

**TIP: ASSEMBLE YOUR GRILL IMMEDIATELY. MISSING OR DAMAGED PARTS  
MUST BE CLAIMED WITHIN 30 DAYS OF PURCHASE.**

### **GRILL SAFETY CHECK-LIST**

---

For your family's safety, please check the following:

- READ and UNDERSTAND the owner's manual and safety instructions.
- DO NOT position or operate barbecue under overhang or unprotected construction, against a wall, near aluminum siding, windows, or fencing.
- CHECK that the regulator nipple is centered into the LP tank valve. Do NOT cross thread this connection. Cross threading may result in a fire, or explosion at the tank connection.
- PERFORM LEAK TEST on all connections as specified in this user manual. Leak Checks should be performed on all new BBQ's even if assembled by an assembler or gas technician. Leak checks should be performed frequently thereafter.
- BEFORE OPENING THE GAS SUPPLY, ensure the lid is open, control knobs are in "OFF" position, gas is turned off, and the regulator is attached to tank correctly. Then follow the PROPER LIGHTING PROCEDURE as shown in the manual. If above steps are not followed, you may experience low flames, or other performance issues.
- Beware HOT SURFACES including lid, lid handle, side tables, and control panel. Wear protective gloves while barbecuing.
- Remove and Clean the QUICK CLEAN™ Grease collection Tray, QUICK CLEAN™ grease cup, and the Even Heat™ Heat Distribution plates, to avoid grease fires and flare ups.
- Remove and Clean the EVEN HEAT™ Burners to avoid flash fires caused by spider webs and blockages.



**DURABILITY • POWER • PERFORMANCE**

# SAFE USE & CARE MANUAL

**THIS MANUAL MUST REMAIN WITH THE PRODUCT AT ALL TIMES**

To ORDER non-warranty replacement parts or accessories,  
or to register your warranty, please visit us on the web at  
**[www.colemanbbqs.com](http://www.colemanbbqs.com)**

---

## **⚠ CAUTION**

Read and follow all safety statements, assembly instructions, use and care directions before attempting to assemble and cook.

---

## **⚠ INSTALLER OR ASSEMBLER/ CONSUMER**

This manual should be kept with the BBQ at all times.

---

## **⚠ WARNING**

Failure to follow all of the Manufacturer's instructions could result in hazardous fires, explosions, property damage, or serious personal injury or even death.

Follow all leak check procedures carefully prior to operation of barbecue, even if grill was dealer assembled. Do not try to light this barbecue without reading the Lighting Instructions section of this manual.

---

## **⚠ DANGER**

1. If you smell Gas:
  - a. Shut off gas to the appliance
  - b. Extinguish any open flame
  - c. Open lid
  - d. If odor continues, keep away from the appliance and immediately call your gas supplier or your fire department
2. Do not store or use gasoline or other flammable liquids or vapours in the vicinity of this or any other appliance.
3. An LP cylinder not connected for use shall not be stored in the vicinity of this or any other appliance.

---

## **⚠ CAUTION**

IN DIRECT SUN, AND IN OPERATION, YOUR BBQ'S STAINLESS STEEL AND PAINTED STEEL PARTS CAN BECOME VERY HOT.

**THIS BARBECUE IS FOR OUTDOOR USE ONLY**

## CAUTION

Some parts may contain sharp edges, especially as noted in the manual. Wear protective gloves during assembly and usage of this appliance.

For residential use ONLY. Do not use for commercial cooking.

## WARNING

Do not attempt to repair or alter the hose and regulator or valve assembly for any assumed defect or for any type of retro fit or conversion. Any modifications to this assembly will void your warranty and create the risk of a gas leak and fire. Use only authorized replacement parts supplied by the manufacturer, for your model.

To ensure your satisfaction and for follow-up service,  
register your BBQ online at  
[www.colemanbbqs.com](http://www.colemanbbqs.com)

## TABLE OF CONTENTS

<b>Installation/ Additional warnings</b>	<b>1</b>
<b>Gas Hook-Ups and Warnings</b>	
LP cylinder requirements	<b>2</b>
LP cylinder removal, transport and storage	<b>3</b>
LP cylinder filling	<b>3</b>
<b>Safety Hose and Regulator:</b>	
Connecting regulator to LP cylinder	<b>4</b>
Regulator flow limiting device (Propane)	<b>4</b>
Resetting the regulator flow limiting feature	<b>4</b>
<b>Leak Testing</b>	<b>5</b>
<b>Natural Gas Models</b>	<b>6</b>
Resetting flow limiting device (Natural Gas)	<b>6</b>
<b>Operation- Lighting instructions</b>	<b>7</b>
<b>Operation- To extinguish</b>	<b>8</b>
<b>Prevention</b>	
Burner Flame Check	<b>9</b>
Flare-Ups	<b>9</b>
Grease Fires	<b>9</b>
Flash-Back Fires	<b>10</b>
<b>Troubleshooting</b>	
Instastart™ Ignition	<b>11</b>
Even Heat™ burners	<b>11</b>
<b>Care and Cleaning</b>	<b>13</b>
Seasoning Cooking Grates	<b>14</b>
<b>Storing your barbecue</b>	<b>15</b>
<b>Start Grilling</b>	
Barbecue Cooking Methods and Grilling Tips	<b>16</b>
BBQ control settings	<b>16</b>
<b>General Side Burner / Sear Stove Tips</b>	<b>18</b>
<b>Quick Check™ Fuel Gauge</b>	<b>18</b>
<b>Easy Read 60 Minute Timer</b>	<b>18</b>
<b>Warranty and Service</b>	<b>21</b>

## INSTALLATION

Installation must conform with local codes or, in the absence of local codes, with either the National Fuel Gas Code, ANSI Z223.1/NFPA 54, Natural Gas and Propane Installation Code, CSA B149.1, or Propane Storage and Handling for Recreational Vehicles, ANSI A 119.2/NFPA 1192, and CSA Z240 RV Series, Recreational Vehicle Code, as applicable.

## ADDITIONAL WARNINGS

### Minimum clearance to adjacent combustibles materials:

**Minimum of 36" (91.44 cm) from furthest protruding edge on all sides of the barbecue.**

- **DO NOT** operate this barbecue under or near any overhanging or unprotected construction, aluminum siding, windows, or fencing.
- **DO NOT** use in enclosed spaces such as carport, garage, porch or covered patio.
- **DO NOT** obstruct the flow of combustion and ventilation air to the barbecue.
- **DO NOT** place Barbecue against a wall or other solid structure
- **DO** always keep the area around this barbecue clean and clear of any and all combustibles materials such as gasoline or other inflammable liquids, paper or oily rags.
- **DO** remember this barbecue is for **outdoor use only** and is **not** for use on any boat or recreational vehicle.
- **DO** use this barbecue outdoors in a well-ventilated area, at least 36" (91.44 cm) from any dwelling or building.
- **DO** always close LP cylinder valve and remove coupling nut before moving LP cylinder from specified operating position.
- **DO** check burner flames regularly.
- **DO NOT** attempt to light burner with lid closed. A buildup of non-ignited gas inside a closed barbecue is hazardous.
- **DO NOT** leave your barbecue unattended while in operation.
- **DO NOT** use while under the influence of drugs or alcohol.
- **DO NOT** store any spare L.P. (propane) cylinder, full or empty, under or near your barbecue.
- **DO NOT** allow children or pets to play anywhere near the barbecue.
- **DO NOT** block ventilation holes in the sides or back of barbecue.
- **DO NOT** use charcoal or ceramic briquettes in this gas barbecue.
- **DO NOT use barbecue until a leak-test and a safety check is completed**

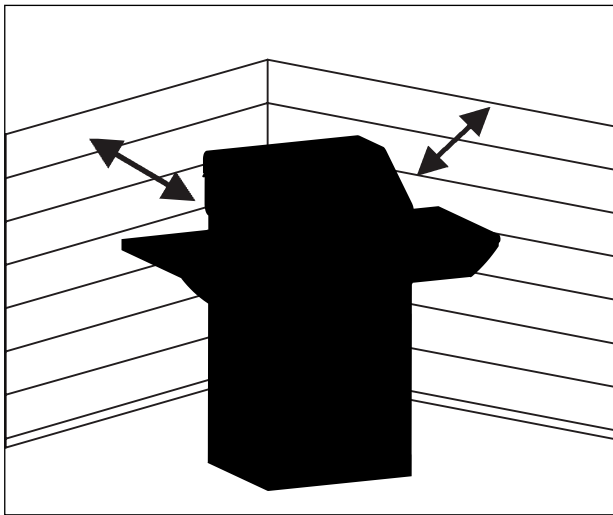

Minimum clearance of 36" on both sides and rear of the barbecue.

## L.P.GAS CYLINDER REQUIREMENTS

**DO NOT connect to a propane cylinder exceeding 9.1 kg (20 lb) capacity or use a cylinder with any other type of cylinder valve connection device.**

LP-gas supply cylinder must be constructed and marked in accordance with the specifications for LP-gas cylinders of the U.S. Department of Transportation (DOT) or the National Standard of Canada, CAN/CSA-B339, Cylinders Spheres and Tubes for the Transportation of Dangerous Goods.

## GAS HOOK-UP'S AND WARNINGS

### (LP) LIQUID PETROLEUM GAS

- LP gas is nontoxic, odorless and colorless when produced. **For Your Safety**, LP gas has been given an odor (similar to rotten cabbage) so that it can be smelled.
- LP gas is highly flammable and may ignite unexpectedly when mixed with air.

#### LP cylinder requirements:

- Use LP cylinder **only** with these required measurements:
- 12" (30.5cm) (diameter) x 18" (45.7 cm) (tall) with 20 lb. (9 kg) capacity maximum.
- LP cylinders must be constructed and marked in accordance with specifications for LP cylinders of the U.S. Department of Transportation (DOT) or the National Standard of Canada, CAN /CSA-B339, Cylinders spheres and tubes for transportation of dangerous goods. See LP cylinder collar for marking.

#### LP cylinder valve must have:

- **Shut-off valve** with a correct cylinder valve output as specified in current standards. ANSI Z21.58-2015 / CSA 1.6-2015 Outdoor Cooking Gas Appliances.
- Type 1 outlet compatible with regulator or grill. The type 1 valve is easily recognized by the large external thread on the outside of the valve.
- Safety relief valve with direct connection to the vapour space of the cylinder.
- **UL listed Overfill Protection Device (OPD)**. This OPD safety feature is identified by a unique triangular hand wheel. Use only LP cylinders equipped with this type of valve.
- A device **for vapor withdrawal**.
- A **collar to protect the LP tank shut off valve**.
- A **ring on the bottom** of the LP tank to secure it to the support assembly.
- Place dust cap on cylinder valve outlet whenever the cylinder is not in use. Only install the type of dust cap on the cylinder valve outlet that is provided with the cylinder valve. Other types of caps or plugs may result in leakage of propane.

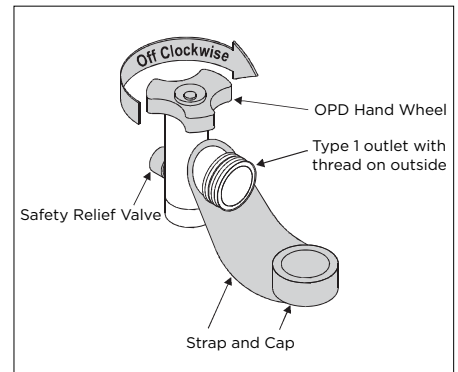

### **⚠ WARNING**

**Any attempt to connect a regulator to any connectors other than the mating TYPE -1 connector could result in fires, explosions, injuries, or property damage. Use only LP cylinders equipped with this type of valve.**

**DO NOT connect to a propane cylinder exceeding 9.1 kg capacity or use a cylinder with any other type of cylinder valve connection device.**

**Before opening LP cylinder valve, check the coupling nut for tightness.**

### **DANGER**

- NEVER store a spare LP cylinder, empty or full, under or near the appliance.
- Never fill a cylinder beyond 80% full.
- An over filled or improperly stored cylinder is a hazard due to possible gas release from the safety relief valve. This could cause an intense fire or explosion with risk of property damage, serious injury or death.
- Do not store objects or materials inside the barbecue cart enclosure that would block the flow of combustion air to the underside of either the control panel or the burner box.
- If you see, smell or hear gas escaping, immediately get away from the LP cylinder/appliance and call your fire department.



## LP GAS WARNINGS:

---

- Always turn cylinder valve off when the barbecue is not in use.
- Always handle the tank valve with the utmost care.
- Never connect an unregulated LP gas cylinder to the barbecue
- Always keep the cylinder, in use, securely fastened in an upright position
- Never expose the cylinder to direct sunlight or excessive heat.
- Never insert any kind of object into the valve outlet as this may cause damage to the Backcheck. A damaged Backcheck can leak resulting in fires, explosions, property damage, severe injuries or death.
- Do not store an LP cylinder in enclosed spaces such as a carport, garage, porch, covered patio or other building. Make sure the storage area has a lot of ventilation.
- Do not store an LP cylinder in an area where children play.

## L.P. CYLINDER REMOVAL, TRANSPORT AND STORAGE

### Before disconnecting the LP cylinder:

1. Turn "OFF" all control knobs and the LP cylinder valve.
  2. Turn coupling nut counterclockwise by hand only - do not use tools to disconnect. Remove LP Cylinder from inside cart.
  3. Install safety cap onto LP cylinder valve. Always use cap supplied with tank valve.
- Failure to use safety cap as directed may result in serious personal injury and/or property damage.

---

### **WARNING**

**When transporting and storing the cylinder, make sure it is in an upright position and not on its side. Do not smoke around cylinder, especially when transporting in a vehicle.**

---

## L.P. CYLINDER FILLING

- Use only licensed and experienced dealers.
- **Ensure that the dealer checks and tests the tank for leaks after filling**
- LP dealer **must purge new cylinder** before filling.
- Dealer should **NEVER** fill LP cylinder more than 80% of LP cylinder volume. Volume of propane in cylinder will vary by temperature.
- Do not release liquid propane (LP) gas into the atmosphere. This is a hazardous practice.
- To remove gas from LP cylinder, contact an LP dealer or call a local fire department for assistance.

---

### **WARNING**

**If the above instructions are not completely adhered to, it could cause a fire/explosion, resulting in death or serious injury, or property damage.**

### **CAUTION**

**A frosty regulator indicates gas overfill. Immediately close LP cylinder valve and call local LP gas dealer for assistance.**

---

## SAFETY HOSE AND REGULATOR

### PROPANE MODELS:

Your Barbecue is designed to operate on L.P gas at a pressure of 2.74Kpa (11" water column). A regulator preset to this pressure is supplied with your Barbecue.

### QCC-1 QUICK CLOSING COUPLING

All models are designed to be used with an LP gas cylinder equipped with the new QCC-1 Quick Closing Coupling system.

The QCC-1 system incorporates new safety features required by the Canadian Standards Steering Committee.

- Gas will not flow until a positive connection has been made
- A thermal element will shut off the flow of gas between 240 degrees and 300 degrees F.
- When activated, a Flow Limiting Device will limit the flow of gas to 10 cubic feet per hour.

### Connecting Regulator to the LP Cylinder

1. LP cylinder must be properly secured onto grill.
2. Turn all control knobs to the OFF position.
3. Turn LP cylinder OFF by turning hand-wheel clockwise to a full stop.
4. Remove the protective cap from LP cylinder valve. Always use cap and strap supplied with valve.
5. Hold regulator and insert nipple into LP cylinder valve. Hand tighten the coupling nut. Hold the regulator in a straight line with LP cylinder valve so as not to cross-thread the connection.
6. Turn the coupling nut clockwise and tighten to a full stop. The regulator will seal on the back-check feature in the LP cylinder valve, resulting in some resistance.

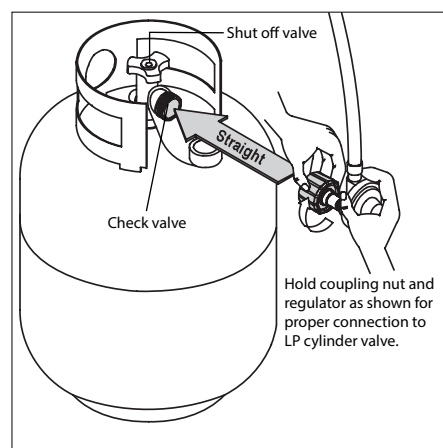
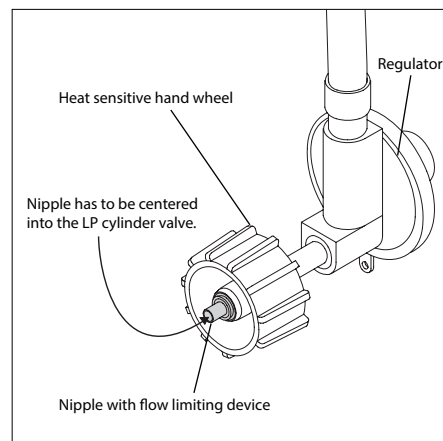

### NOTE:

If you cannot complete the connection, disconnect regulator and repeat steps 5 and 6. If you are still unable to complete the connection, **do not use this regulator!**

### **⚠ DANGER**

**Do not insert any tool or foreign object into the valve outlet or safety relief valve. You may damage the valve and cause a leak. Leaking propane may result in explosion, fire, severe personal injury, or death.**

### Regulator Flow Limiting Device

If you are experiencing any of the following performance issues you may have activated the flow limiting feature in your regulator:

- Burners not getting hot enough
- Low or incomplete burner flames
- Low gas pressure
- Burners not staying lit

### Resetting the Regulator Flow Limiting feature (Propane Barbecues)

1. With all control knobs and the gas source in the "OFF" position, open the BBQ lid.
2. Disconnect the hose and regulator from the propane tank.
3. Turn all BBQ control knobs to the "MAX" ( 🔥 ) position, and let stand for 1-3 minutes, allowing all excess gas in valves and manifold to dissipate.
4. Turn all BBQ control knobs back to the "OFF" position.
5. With the BBQ lid still OPEN, reconnect the hose and regulator to the propane tank- Do not cross thread the connection. Hand-tighten only.
6. Check all hose connections to ensure that a positive seal has been made.



7. Slowly turn "ON" the propane gas supply, 1/4 to 1/2 a turn.
8. Wait approximately 5 seconds for the hose and regulator pressure to stabilize (to prevent the flow limiting device feature from being re-activated).
9. Turn the selected burner control knob, to the "MAX" ( 🔥 ) position.
10. Press the Electronic ignition button, or use the match and match holder, or a BBQ lighter to ignite the selected burner.

**Avoid activating the Flow Limiting Feature** by following the proper start up and shut down procedures and performing a complete leak test and safety check to ensure that there are no leaks in the system, and that a positive connection has been made between the gas source and manifold assembly.

## LEAK TESTING THE VALVE, HOSE AND REGULATOR ASSEMBLY

1. Turn all grill control knobs to "OFF".
2. Ensure that the regulator is tightly connected to LP cylinder.
3. Brush soapy solution onto hose and regulator and all connections from the LP tank to the main and side burner manifold.
4. Completely open LP cylinder valve by turning hand wheel counterclockwise. If you hear a rushing sound, turn gas off immediately. There is a leak at the connection. **Correct before proceeding.**
5. If "**growing**" bubbles appear, there is a leak. Close LP cylinder valve immediately and re-tighten connections. **If leaks cannot be stopped do not try to repair.** Call for replacement parts. Order new parts by providing the serial number, model number, name and part number of items required (see parts list) to a **Coleman® Customer Care Agent 1-800-275-4617.**
6. Always close LP cylinder valve after performing leak test by turning hand wheel clockwise.

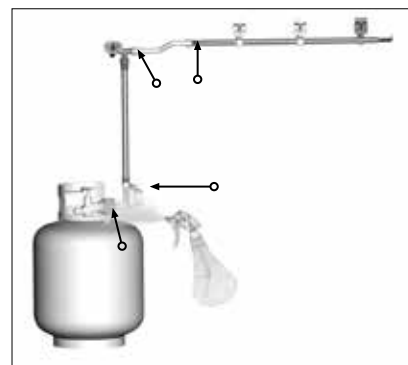

### LP Cylinder Leak Test For Your Safety

**ATTENTION: Leak Test must be repeated each time the LP cylinder is exchanged or refilled.**

- Do not smoke during leak test.
- Do not use an open flame to check for gas leaks
- BBQ must be leak tested outdoors in a well ventilated area, away from ignition sources such as gas fired electrical appliances. During leak test, keep your BBQ away from open flames or sparks.
  - Use a clean paint brush and a 50/50 mild soap and water mixture.
  - Brush soapy solution onto areas indicated by arrows in figure A.

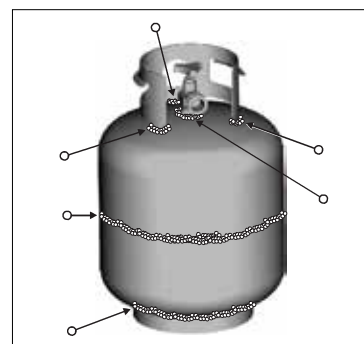

### **⚠ ATTENTION**

**If it is evident there is excessive abrasion or wear, or the hose is cut, it must be replaced prior to the outdoor cooking gas appliance being put into operation. The replacement hose assembly shall be that specified by the manufacturer.**

### **⚠ WARNING**

**For all new, at home, natural gas connections please contact a certified gas technician to install your natural gas barbecue.**



# NATURAL GAS HOOK-UPS AND WARNINGS

## FOR NATURAL GAS MODELS ONLY

All Coleman® Natural Gas Barbecues come equipped with a 10' Natural Gas hose with a quick connect socket connection. This will allow you to attach your Barbecue to your residential gas line.

### To Connect

1. Push back the sleeve on the Quick Connect socket, insert the plug and release the sleeve.
2. Push the two pieces together until the sleeve snaps forward, to lock the plug in the socket.

### To Disconnect

1. Push sleeve back and pull the plug out.

### Testing For Gas Leaks

#### Before attempting to operate this Grill:

- Always confirm that all burner control knobs are in the "OFF" position.
- Always connect the gas supply hose first, open lid and then open the gas shutoff valve.
  - Always use a brush or spray bottle to apply a 50/50 solution of liquid soap and water to all connection points, to test for gas leaks. Never use a match or open flame for that purpose.
  - Always look for bubbles to appear, as the appearance of bubbles will indicate a gas leak.
  - Always turn off the gas immediately and tighten the connection, if you find that a leak has been detected.
  - Before lighting the grill, always repeat this procedure until no further gas leaks are found.
  - If a leak cannot be stopped, do not attempt to light the grill. Always contact a certified Natural Gas technician for assistance or the Coleman® Customer Care Agent 1-800-275-4617.

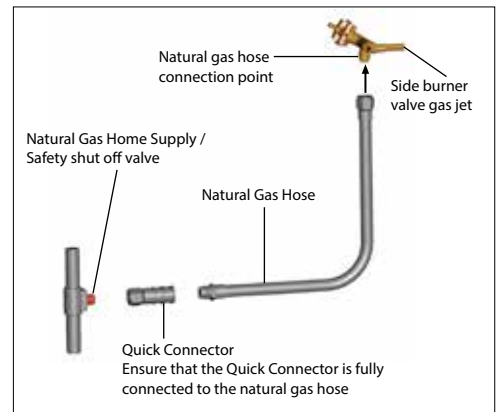

### NEW Natural Gas Barbecue

If you are experiencing poor natural gas barbecue performance, including but not limited to low flame, low heat or poor heat distribution, please review the following information:

- Always consult the Rating Label on the back of the barbecue to confirm that it has already been configured to burn natural gas.
- If experiencing performance issues with a brand new barbecue hooked up to an older natural gas home connection, it is possible that the natural gas supply line is not able to supply up to the essential 85,000 BTU's required (depending on the model). Please contact Coleman® Customer Care for requirements and then consult with your certified natural gas technician.
- All gas supply plumbing must be carried out by a qualified service agency. The Supply connection shall be carried out in accordance with provincial authorities having jurisdiction, and in accordance with CAN/CGA 1-B149.1 & 2 installation code requirements.
- A shut off valve must be installed between the barbecue and the main supply. **For natural gas, use a 3/8" or 1/2" natural gas supply line capable of an input of up to 85,000 BTU's (depending on the model).**
- **When conducting pressure test always isolate the barbecue from the gas supply piping system by disconnecting the barbecue and closing its individual manual shutoff valve. The gas supply piping system should be tested at pressures which exceed 1/2 psi (3.5kPa).**
- All gas supply plumbing must be able to supply 7" water column to the barbecue **WITH ALL BURNERS IN OPERATION.**

### Resetting Flow Limiting Device (Natural Gas Models)

If you are experiencing low heat performance issues, you may have activated the flow limiting feature in your home's natural gas connection. To reset the flow limiting device, follow these steps:

1. Open the lid of your BBQ
2. Ensure that the control knobs are in the OFF/CLOSED position
3. Ensure that the Natural Gas Supply valve is in the OFF/CLOSED position at the Home Connection
4. Disconnect the Natural Gas Supply hose by separating the Quick Connect Assembly at the Home connection
5. Turn all control knobs to the ON/OPEN position (MAX)
6. Reconnect the Natural Gas Supply hose by securing the Quick Connect assembly connection
7. Using your hands only, check all connections to confirm that positive seal has been made
8. Turn the knobs to the OFF/CLOSED position
9. Slowly turn ON the Natural Gas Supply valve to the ON/OPEN position
10. Wait 30 seconds for the gas pressure to stabilize (60 seconds in cold weather)
11. Turn ON/OPEN the selected burner control knob, to the MAX position and wait 3 to 5 seconds
12. Press the Electronic ignition button, or use the match and match holder to ignite the selected burner (BBQ lighter)
13. Repeat steps if not successful on first try.

## **⚠ WARNING**

**ALL Coleman® BBQ's are sold either NATURAL GAS or PROPANE READY and are not convertible from one gas source to another.**

## OPERATION – LIGHTING INSTRUCTIONS

### Lighting – EVEN HEAT™ Burners:

1. Open the lid
2. Make sure all burner control knobs are turned “OFF”. (Push the control knob in and turn clockwise, to ensure that the control knob is in the “OFF” position.)
3. Turn the LP tank valve ON slowly (turn counter clockwise). Wait for pressure to stabilize for 5 seconds.
4. Push in and turn selected control knob counter clockwise to the MAX position (  ).
5. Push the INSTASTART™ ignition button. You should hear rapid clicks. Repeat if necessary.
6. Check that the burner is lit
7. After the burner is lit you can turn on the other burner control knobs.

If the EVEN HEAT™ burner fails to light properly within 3-5 seconds, turn the burner control knob off. Also turn off the L.P cylinder valve. Wait five minutes before attempting to light the burner again. This will allow time for released gas to disperse.

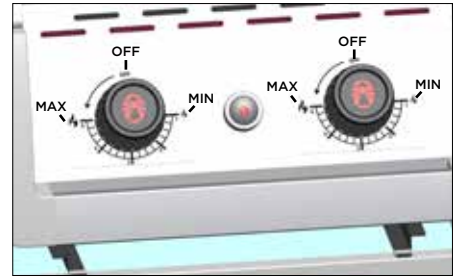

### WARNING

**The burner control knobs must be in the “OFF” position before turning on the liquid propane cylinder tank valve. If left in the “ON” position, when the LP cylinder valve is opened, the “Flow Limiting Device” feature will activate, limiting the flow of gas from the LP cylinder. If this should occur, turn “OFF” the LP cylinder valve and burner control knobs and follow the “Resetting the flow limiting device instructions”.**

### WARNING

**Never stand with your head directly over the barbecue when preparing to light the main burners, to prevent possible bodily injury.**

### Match-lighting—EVEN HEAT™ Burners

Repeat steps 1-3 “Lighting - EVEN HEAT™ Burners” above.

4. To match light: push in and turn the far left burner control knob counter clockwise to the MAX position (  ).
5. Immediately strike a match or use a butane lighter, and position through the lighting hole on the left side of the burner box. Shown in figure A. Check to ensure that the burner is lit.
6. To light the other burners, press in and turn the nearest control knob. The flame will track around the burner and light via the carryover tubes. Allow the grill to preheat with the grill lid closed for 10-15 minutes before cooking.

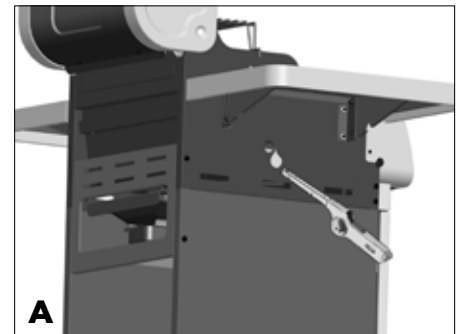

Model may not be exactly as shown.

### Lighting- Side Burner / Sear Stove (if applicable)

1. Open the side burner lid
2. Check that the side burner valve is turned “OFF”.
3. Turn the LP tank valve ON slowly (turn counter clockwise). Wait for pressure to stabilize for 5 seconds.
4. Push down and turn the side burner control valve to MAX (  ).
5. Press the INSTASTART™ Ignition button. You should hear rapid clicks. Check to ensure that the burner is lit. Repeat if necessary.

**The side burner lid is for storage only. Wait until cool before closing.**

### CAUTION

**Side burner flame may be difficult to see on a bright sunny day**

---

**⚠ CAUTION**

**If side burner fails to light immediately, turn burner control knobs “OFF” and wait 5 minutes before re-lighting with a match**

---

**Match lighting the Side Burner / Sear Stove  
(if applicable)**

1. Open the side burner lid
2. Check that the side burner valve is turned “OFF”.
3. Turn the LP tank valve ON slowly (turn counter clockwise).  
Wait for pressure to stabilize for 5 seconds.
4. Put match in a match holder and strike match
5. Push down and turn the side burner control valve to MAX ( 🔥 ).
6. Hold match holder and lit match by left side of side burner.

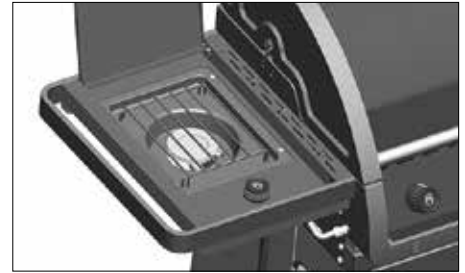

**Side Burner**



**Sear Stove**

\*Models may not be exactly as shown.

---

**⚠ CAUTION**

**If ignition does NOT occur in 5 seconds, turn the burner controls “OFF”, wait 5 minutes and repeat the lighting procedure. If the burner does not ignite with the valve open, gas will continue to flow out of the burner and could accidentally ignite with risk of injury. Turn controls and gas source “OFF” when not in use.**

**⚠ IMPORTANT**

**If you have a Coleman® Even Heat™ Dual Fuel Barbecue, consult the Charcoal Guide for charcoal lighting instructions.**

**⚠ ATTENTION**

**Always preheat barbecue before starting to cook. Light all burners and adjust them to the MAX position for 5 to 10 minutes with the lid closed. Following preheat; adjust the controls to medium setting for most cooking requirements.**

---

**To EXTINGUISH**

1. Push in and turn each burner control knob clockwise to the “OFF” position.
2. Turn off the LP Cylinder valve by turning the hand wheel in a clockwise direction until it stops.

---

**⚠ WARNING**

**If the heat output is too low, the “Flow Limiting Device” may have been activated by a gas leak or improper lighting procedure. If so, turn “OFF” the burner valve and cylinder valve, and perform a “Leak Test”. If there are no leaks, perform a complete regulator Flow Limiting Device reset.**

---

## PREVENTION

### **⚠ ATTENTION**

**Once lit, confirm that the burner is properly lit and that the flame pattern is as desired. If the flame pattern is other than normal, consult the troubleshooting guide for corrective action.**

### Burner Flame Check

Always do a visual check of all burners prior to lighting. The Coleman® EVEN HEAT™ Burners have been factory set for the correct air and gas mixture. The correct flame pattern is shown in figure A. If you experience one of the following symptoms, follow the burner cleaning procedure outlined in the maintenance section of this manual, or reset the regulator Flow Limiting Device:

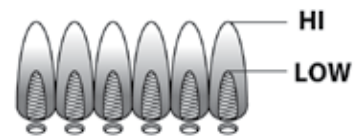

Figure A

- The flames do not appear to be uniform throughout the burner tube
- The smell of gas in conjunction with the burner flames appearing yellow and lazy
- Barbecue does not reach temperature
- Barbecue heats unevenly
- One or more of the burners do not ignite.

### Flare-Ups

Flare-ups sometimes occur when food drippings fall onto the hot heat distribution plates or burners, and ignite. Some flare-up is normal and desirable, as it helps impart the unique flavours associated with grilled foods. Controlling the intensity of the flare-ups is essential to avoid burned or unevenly cooked foods, and to prevent un-controlled grease fires from erupting.

### **⚠ WARNING**

**Always monitor the barbecue carefully while cooking and turn the flame level to low, or off, if flare-ups intensify.**

#### **To keep flare-ups to the desired level, do the following:**

- Trim fat from meats before grilling.
- Always cook with the lid down, and cook at the lowest most efficient heat setting.
- Ensure that the heat distribution plates, cooking grates and the bottom of the firebox are cleaned regularly to eliminate grease build up.
- **Flare-ups can increase the temperature of the barbecue and add to the buildup of grease, increasing the risk of a grease fire. Keeping your barbecue clean, and regularly checking for obstructions, including; spider webs, will ensure that your family is protected from serious safety hazards, such as “Flash-Back” and “Grease Fires”.**

### **⚠ WARNING**

**Old grease accumulated on key parts, such as heat plates, cooking grates and the lower burner box, is highly flammable. Avoid dangerous flare-up and grease fires by regularly removing and cleaning key parts.**

### Grease Fires

#### Characteristics of a Grease Fire

- A fire burning inside the **barbecue** burner box that may become uncontrollable, if not monitored
- Usually accompanied by high flames, a lot of smoke and black soot

#### Prevent Grease Fires:

- Remove grease build-up on key parts such as heat distribution plates, cooking grates, and burner box
- Frequently cleaning the QUICK CLEAN™ grease collection plate and grease cup
- Always reducing cooking temperature to MED or LOW heat, following PREHEAT.
- Performing a burn-off of grease prior to each barbecue session, by adjusting your barbecues temperature to “HI”, and letting it stand for 10-15 minutes with the lid closed.

## Flash-Back Fires

Spiders and insects are attracted to the smell of gas, and often build nests inside your barbecue's burners, causing the potential risk of a Flash-Back fire. Lighting your burners without first cleaning the venturi tubes, port holes, and interior of your burners, can lead to a serious Flash-Back fire resulting in property damage and/ or personal injury.

### Characteristics of a Flash-Back fire

- Burners will burn with large yellow flames
- Hot or melting control knobs
- A fire or flash of fire burning outside of the burner box, usually visible behind or under the control panel
- Burners may not light

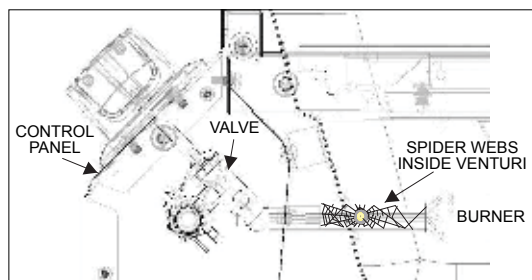

### Prevent “Flash-Back Fires” by:

- Remove burners to clean and clear blockages
- Clean tip of valve gas jet to remove any build-up or blockages



### **WARNING:**

**At first sight of yellow, unruly flames, or poorly lit burners, shut down your BBQ and remove and clear obstructions, like insect webs, from your burners and valve gas jet.**

## FOR YOUR SAFETY

- **DO NOT** throw water on a fire
- **DO** keep baking soda handy to extinguish a fire
- **DO** follow all warnings and safety checks outlined in the **Safety & Care Manual** and **Assembly Manual**
- **DO protect your family and home by performing the cleaning and maintenance steps outlined in this manual**

For more information regarding these issues please visit us at [www.colemanbbqs.com](http://www.colemanbbqs.com)

### Resolving InstaStart™ Ignition Performance Issues

1. Check the **electronic ignition box** for un-plugged **electrode wires**. Push-in firmly.
2. Check the wires for damage.
3. Replace the **battery** in the electronic ignition box. Positive end facing outwards.
4. Check **battery cap** for proper threading.
5. Check that all electrodes (attached to the burners) spark when the **Instastart™** button is pressed.
6. Check to make sure that the **Instastart™** ignition button, located on the control panel, has continuous clicking sound when pressed.
7. Check to ensure that the tip of the electrode is positioned close enough to the burner port holes to light correctly.
8. Check electrodes for cracks in the porcelain insulator.

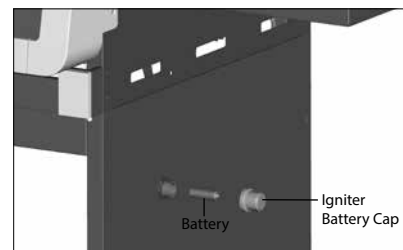

Replace the battery. Open the Lid. Press Ignition button and listen for rapid clicks.

#### COLEMAN® EVEN HEAT™ SMALL SPACES

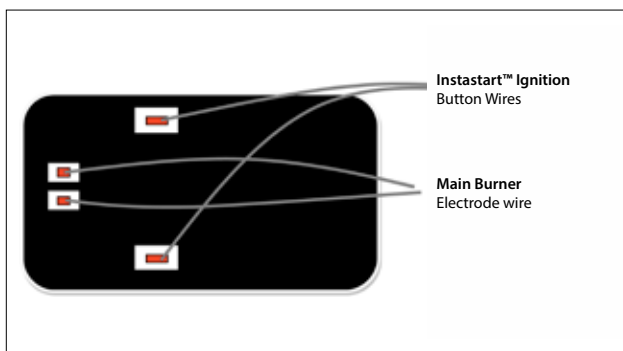

#### COLEMAN® EVEN HEAT™ 3 BURNER / DUAL FUEL

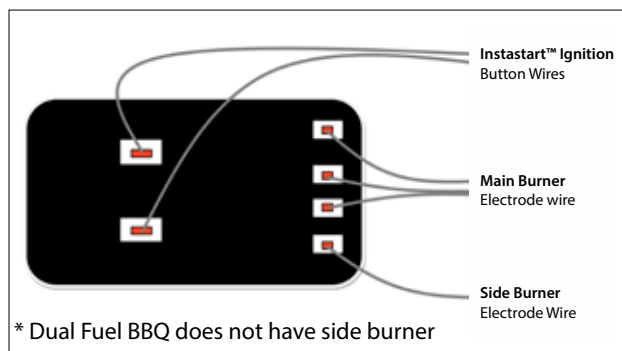

#### COLEMAN® EVEN HEAT™ BARBECUE 4 BURNER

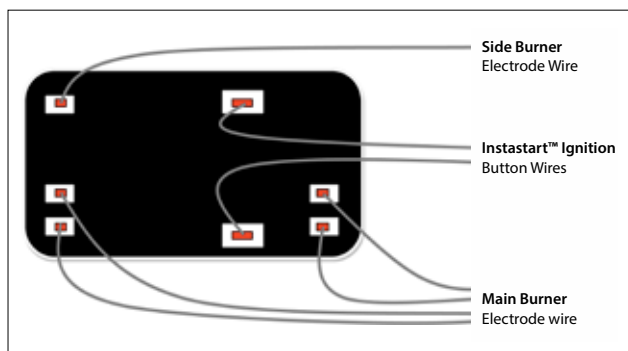

PROBLEM	IDENTIFYING THE CAUSE:
Burners will not light (with igniter or match)	<ul style="list-style-type: none"> <li>• Positive connection has not been made between the tank and the regulator.</li> <li>• Low or out of propane</li> <li>• Gas supply valve is turned off</li> <li>• EVEN HEAT™ Burners are not properly seated over valve orifices</li> <li>• Flow limiting device in regulator has been activated. See Resetting the Regulator Flow Limiting Device on page 4 and page 6.</li> </ul>
Burners will not light with the igniter (No spark)	<ul style="list-style-type: none"> <li>• Ignition battery is dead or corroded</li> <li>• Loose Electrode Wires</li> <li>• Broken electrode - ceramic casing around electrode damaged</li> <li>• Faulty Electronic Ignition box</li> </ul>
Fire at control knob and control panel = Flash Fire	<ul style="list-style-type: none"> <li>• EVEN HEAT™ burner and/or burner tubes have a blockage</li> <li>• EVEN HEAT™ burner is improperly seated over gas jet</li> </ul>
Yellow smokey flames/ gas odour can be smelled	<ul style="list-style-type: none"> <li>• EVEN HEAT™ burner and/or burner tubes have a blockage</li> </ul>

PROBLEM	IDENTIFYING THE CAUSE:								
Flame blows out on LOW	<p><b>PROPANE MODELS:</b></p> <ul style="list-style-type: none"> <li>Flow limiting device in regulator has been activated either due to a leak or improper lighting. See page 4.</li> <li>Low or out of propane</li> <li>High Wind condition - Adjust BBQ to shield from wind</li> <li>EVEN HEAT™ burner improperly seated on gas jet</li> </ul> <p><b>NATURAL GAS MODELS:</b></p> <ul style="list-style-type: none"> <li>Installation issues. See Natural Gas Hook-Ups and Warnings on page 6.</li> <li>Not using the Natural Gas Hose supplied with this BBQ.</li> <li>Flow limiting device has been activated. See page 6 (Natural Gas models).</li> </ul>								
Low heat	<p><b>PROPANE MODELS:</b></p> <ul style="list-style-type: none"> <li>Flow limiting device in regulator has been activated either due to a leak or improper lighting. See page 4.</li> <li>Make certain the problem is isolated to only one burner. If it appears so, the EVEN HEAT™ burner and/or burner tubes are blocked</li> <li>Check for a bent or kinked fuel hose</li> <li>In colder temperatures preheat for longer periods.</li> </ul> <p><b>NATURAL GAS MODELS:</b></p> <ul style="list-style-type: none"> <li>Not using the Natural Gas Hose supplied with this BBQ.</li> <li>Gas pressure is affected by the length and piping size of the gas line from the home. Follow the recommendations in the chart below. See natural gas hook-ups and warnings on page 5.</li> </ul> <table border="1" data-bbox="625 936 1474 1048"> <thead> <tr> <th colspan="2">FROM HOME TO BBQ</th> </tr> </thead> <tbody> <tr> <td>Up to 25'</td> <td>3/8" diameter</td> </tr> <tr> <td>26-50'</td> <td>1/2" diameter</td> </tr> <tr> <td>51- 100'</td> <td>2/3" of run 3/4" or 1/3" of run 1/2"</td> </tr> </tbody> </table>	FROM HOME TO BBQ		Up to 25'	3/8" diameter	26-50'	1/2" diameter	51- 100'	2/3" of run 3/4" or 1/3" of run 1/2"
FROM HOME TO BBQ									
Up to 25'	3/8" diameter								
26-50'	1/2" diameter								
51- 100'	2/3" of run 3/4" or 1/3" of run 1/2"								
Low or incomplete flame (assuming burners and Venturi tubes are free and clear of blockages)	<p><b>PROPANE MODELS:</b></p> <ul style="list-style-type: none"> <li>Flow limiting device in regulator has been activated. Flow limiting device has been activated. See page 4.</li> </ul> <p><b>NATURAL GAS MODELS:</b></p> <ul style="list-style-type: none"> <li>Installation issues. See Natural Gas Hook-Ups and Warnings on page 6.</li> <li>Not using the Natural Gas Hose supplied with this BBQ.</li> <li>Flow limiting device has been activated. See page 6.</li> </ul>								
Too much heat/ Excessive flare up	<ul style="list-style-type: none"> <li>Grease build up around burner system causing dangerous flare ups and over-heating.</li> <li>Cooking on the "Hi" setting, without adjusting temperature control.</li> <li>Grease collection plate and grease cup need to be cleaned.</li> <li>Covering more than 70% of the cooking surface may cause the BBQ to overheat.</li> <li>Excessive fat on meat and cooking on high temperatures.</li> </ul>								
Inside of lid is peeling - like paint peeling	<ul style="list-style-type: none"> <li>The interior lid is Aluminum not painted. Baked on grease build-up has turned to carbon and is flaking off. Clean thoroughly.</li> </ul>								
Decreasing heat, "popping sound"	<ul style="list-style-type: none"> <li>Out of Propane</li> <li>Burner and/or burner tubes are blocked</li> </ul>								
Humming noise from Regulator	<ul style="list-style-type: none"> <li>Cylinder valve opened too quickly</li> </ul>								
Melting gas supply hose	<ul style="list-style-type: none"> <li>Your BBQ's Gas supply hose and regulator contains a thermal element that will shut off the flow of gas between 240°F and 300 °F, by melting the supply hose and essentially disconnecting from the LP cylinder.</li> <li>Poor ventilation caused by in-appropriate clearance at the sides and rear of the BBQ.</li> <li>Overheating caused by high cooking temperatures and grease build-up.</li> <li>Build up of grease in quick clean grease cup and tray.</li> </ul>								



## CARE AND CLEANING

If you are experiencing any of the following performance or safety issues, including, but not limited to; 1) barbecue not reaching temperature potential, 2) yellow burner flames, 3) the smell of gas, 4) popping noises, 5) delayed burner ignition, 6) uneven heat, 7) flash fires, or 8) grease fires, TURN OFF YOUR barbecue immediately and perform the following COLEMAN® Care and Cleaning regime.

### Care and Cleaning Regime

Cleaning and maintaining your barbecue ensures your families safety, optimal parts performance, and a long life for your barbecue. Perform at the start of the season, and at least twice in-season, more if the barbecue is being used frequently or year-round.



#### CAUTION:

**Always allow sufficient time for the barbecue to cool fully before handling or cleaning any of its parts.**

**STEP ONE:** Remove and/or disassemble the following parts; cooking grates, warming rack, Even Heat™ heat distribution plates, Even Heat™ burners and the Quick Clean™ grease management system.

**STEP TWO:** Follow the care and cleaning instructions outlined below.



#### Burner box

- Use a plastic paint scraper to remove build-up, food residue and ashes inside the barbecue housing and lid.
- If necessary, wash the inside of the barbecue burner box with detergent and water solution. Always rinse and dry thoroughly before re-installing parts.
- For heavily soiled burner boxes use a crumpled piece of aluminum foil to help remove build up.



#### Quick Clean™ Grease Management system channels grease to a removable grease cup for effortless clean-up.

The grease cup and grease tray are located below the burner box of the appliance, accessible from the rear of the barbecue. The grease cup and collection tray should be emptied regularly to prevent possible flare ups, spillage or grease fires.

- Always wait for grease to cool before removing the grease cup or collection tray.
- Use a paint scraper to remove all build-up. Wash the grease collection tray and grease cup with soap and water, rinse and dry thoroughly before replacing.

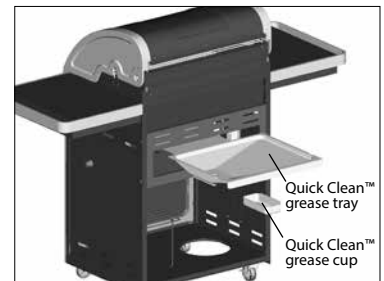

#### Even Heat™ Burners

- Remove the hardware used to assemble the burners to the carryover assembly. (It may be necessary to use WD40 to help loosen difficult to remove hardware)
- Remove your burners from the barbecue
- Brush the surface of the burner to remove surface debris
- Clean the burner port holes using a wire or paperclip to unclog the ports. Do not use any tools that will cause damage to or enlarge the port holes.
- Use a flexible venturi cleaning brush to clean the interior of the burner. Shake any loose debris out of the burner, through the gas inlet.
- Use a cotton swab to remove debris from the valve gas jets
- Re-install the burner. Ensure that the burner covers the valve gas jet.



#### CAUTION:

**Do not use anything larger in diameter than the port hole itself as this may cause damage to the burner port holes.**



#### Sear Stove (if applicable)

- Due to the high intensity of the Sear stove burner, most drippings and food particles that fall onto the burner surface are immediately incinerated. However, some debris and residue may remain. To remove buildup, operate the Sear stove burner for an additional 5 minutes on "MAX".
- If ceramic appears to be wet, remove the burner from the grill. Turn upside down to drain the excess water. Bring indoors and dry thoroughly.
- Avoid impact with hard objects.



### **EVEN HEAT™ Heat Distribution Plates**

Your EVEN HEAT™ Heat Distribution Plates will protect burners from direct drippings of grease, fats and salty marinades, distribute heat evenly across the cooking surface and incinerate grease drippings creating the authentic barbecue flavours we love.

When allowed to accumulate, the build-up of grease may cause a number of safety issues, including flare-ups and grease fires. Failure to follow the steps outlined below may lead to rapid deterioration of this part, moisture damage or rust-through.

**Note: Do not allow grease to build up on the heat distribution plates. Any leftover grease can ignite causing serious flare-up fires or more dangerous and uncontrollable grease fires.**

- Remove and clean heat distribution plates every other time you barbecue, the moment you notice build-up, or after cooking fatty meats including; sausages, hamburgers or pork ribs.
- Use a grill brush to remove buildup. We recommend doing this over a large garbage receptacle.
- Clean away all remaining debris with mild soap and warm water.
- Dry thoroughly.
- Re-install.



### **COLEMAN® DUAL SURFACE CAST IRON COOKING GRATES**

Seasoning cooking grates with vegetable shortening improves cooking performance and heat retention, prevents damage and deterioration due to moisture and humidity, creates a non-stick surface for cooking, and extends the life of your cooking grates.

#### **Tips:**

- Always have vegetable shortening on hand for seasoning your cooking grates.
- Never use your cooking grates until they have been seasoned. Follow the directions outlined in this manual.
- Always prep your cooking grates with a light coating of vegetable shortening or vegetable oil, and preheat on “HI” to the desired temperature.
- Always perform a burn-off and clean up with your grill brush, at the start of your cooking session. Leftover oil on your cooking grates, will help to protect them in between cooking sessions.

#### **How to season your COLEMAN® DUAL SURFACE CAST IRON COOKING GRATES**

1. Brush away build-up with a barbecue grill brush.
2. Wash cooking grates with soap and water. Do not immerse grates in water.
3. Rinse and dry thoroughly with a towel. If cleaning on a very hot day, allow grates to dry in the sun.

**Important:** Never allow cooking grates to soak in water or stay wet.

4. Coat entire cooking grate, top, bottom, sides and each rod with vegetable shortening. DO NOT use salted fat such as margarine, butter, or any non-stick cooking spray. Do not use olive oil as it burns off at high temperatures.
5. Place your COLEMAN® Dual Surface Cast Iron Cooking Grates in position on the barbecue and preheat on “HI” for 20 minutes.
6. Shut down and allow your grates to cool down.
7. When the grates have been allowed to cool, the seasoning process is complete.

When you season your porcelain cast iron cooking grates with vegetable shortening, you are permeating the pores of your cooking grates, to create an improved non-stick surface, better performance and optimal protection against moisture and water damage. With continued care and seasoning your cooking grates will offer years of excellent performance.

#### **STORING YOUR COOKING GRATES**

1. Remove your Dual Surface Cast Iron Cooking Grates.
2. Clean, season, and wrap in a dry cloth
3. Store indoors or in a dry location



### Caring for your Barbecues EXTERIOR SURFACES

ALL MATERIALS including stainless steel, porcelain and black or silver painted steel parts can become stained, soiled and corroded by dirt, pollution, deposits from inappropriate cleaners and especially grease. To protect the appearance and integrity of the surface, routine cleaning is essential. Contaminants vary greatly in their effect on appearance, corrosivity and ease of removal. It may be necessary to identify the contaminant or experiment with various cleaners in order to resolve issues including the removal of free-iron contamination.

- **DO remove** dirt and contamination immediately to avoid permanent damage to stainless steel, porcelain or painted surfaces,
- **DO test** all cleaners on a small inconspicuous area to ensure that it is beneficial for surfaces,
- **DO only use** cleaners made specifically for outdoor products
- **DO use** one of the following methods of cleaning:
  - Warm water and mild soap solution to remove all contaminants
  - Warm water, detergent, solvent solution to remove grease buildup
  - 50/50 mixture of vinegar and water for removing surface dirt and contamination
  - Commercial grade stainless steel cleaner for polishing
- **DO thoroughly rinse off all cleaners, with clean warm water, and dry completely with a soft cloth.**
- **DO only use** a soft clean cloth, when cleaning surfaces to avoid scratching finish. Microfiber cloths are highly recommended
- **DO NOT use** any chloride-containing detergents.
- **DO NOT use** any abrasive cleaners.
- **DO NOT use** any chemical cleaners as they may strip the paint, causing permanent damage
- **DO NOT use** ordinary carbon steel brushes, steel wool or scouring pads as they may leave particles embedded on the surface which can lead to rust
- **DO NOT use** bleach or cleaners containing bleach. If accidental contact occurs wash immediately with baking soda and rinse thoroughly.

For more COLEMAN® Care and Cleaning tips, visit us online @ [www.colemanbbqs.com](http://www.colemanbbqs.com)

### STEP THREE: Storing your barbecue

To avoid the deterioration and degradation of parts, perform the following tasks prior to storing your BARBECUE for the season.

- Remove and clean all Barbecue components as outlined in the Care and Cleaning section of this manual
- Remove cooking grates, wrap them in a towel and store indoors. For porcelain cast iron cooking grates, be sure to season the cooking grates before wrapping in a towel and storing indoors.
- If storing the BBQ away for the winter, or for a prolonged period of time, remove the igniter battery to avoid corrosion
- If storing the Barbecue indoors: the propane cylinder MUST be removed.
- The propane cylinder MUST always be stored outdoors, in a well ventilated area.
- When storing your Barbecue in a garage, you should place a piece of cardboard underneath your Barbecue to protect it from concrete moisture damage.
- If storing the Barbecue outdoors: the propane cylinder valve must be turned "OFF".
- **DO NOT** under any circumstances store the Barbecue with propane tank in the garage or near any heat source.
- Use a BARBECUE cover to help protect your Barbecue
- **Please note:** covering your BBQ will protect it from the effects of snow, rain, animal droppings and more, but will not protect against moisture damage, condensation, and other corrosive agents.



### IMPORTANT

If you have a Coleman® Even Heat™ Dual Fuel Barbecue, consult the Charcoal Guide for charcoal care, cleaning and storing tips.

## START GRILLING!



### **WARNING:**

**Always observe safe food handling and safe food preparation practices when using this Barbecue, to prevent food-borne illnesses.**

### **Avoiding Cross Contamination**

Sanitize counters, equipment and utensils after handling raw meat, seafood or poultry. Rinse with a dilute chlorine bleach solution, one teaspoon to a quart of water. Avoid cross-contamination in preparing food.

- Always cook foods adequately. Undercooked foods can retain bacteria, especially if thawed or exposed to warm conditions prior to cooking
- Always use a meat thermometer to confirm that foods have been fully cooked.
- Always use separate plates and utensils for the handling of raw food. Never place raw food and cooked food on the same plate, and never place cooked food on a plate that was used for handling raw food.
- Always carefully wash all plates and utensils used to handle raw food before using them to handle cooked food.
- Always wash all vegetables, seafood and poultry before cooking.
- Always leave uncooked foods in the refrigerator until you are ready to start cooking
- Always marinate meat in the refrigerator. Always dispose of the excess marinade, and never reuse it.
- Always preheat your barbecue to the desired temperature before cooking, and clean all grease and food residue before using the cooking grates.

### **GRILLING TIPS:**



### **ATTENTION:**

**Cooking grates must be seasoned before first use. Refer to the instructions on p. 14. For best results use vegetable shortening.**

A few helpful hints will ensure that your grilling results are perfect every time!

- Apply a light coating of cooking oil or vegetable shortening to your cooking grates before grilling, to prevent foods from sticking.
- Always remove and clean heat distribution plates before preheating.
- Trim excess fat from meats and slit the remaining fat at two-inch increments to avoid flare-ups and curling. Fatty meats may be cooked indirectly on lower heat settings.
- Baste meat with barbecue sauce or other sugar-based sauces only during the last few minutes of cooking to prevent burning.
- Always preheat the appliance on "HI" to the desired temperature before adding food.

Coleman® Even Heat™ Barbecues have been designed to offer a range of temperatures and unlike most grills, can quickly reach searing temperatures:

- **To Preheat:** depending on the foods you are preparing, always preheat your grill to the temperature required.
- If lower temperatures are required for slow cooking foods such as; chicken and pork ribs, ensure that you do not preheat to very high temperatures. The Dual Surface Cast Iron Cooking Grates have the best heat retention and will hold very high temperatures longer. Always target the temperature you need during preheat.

- Cook similar portion sizes together, so that they all cook evenly
- Always ensure that the temperature is adjusted following preheat. "MAX" is intended for fast pre-heating of the appliance, searing steaks and other cuts of meat.
- Medium heat is intended for most grilling, baking and roasting
- Low heat is intended for warming, slow cooking, smoking or cooking delicate foods
- Never pierce foods while they are cooking on the Barbecue, as this will dry them out
- Turn foods infrequently. Turn food only once, halfway through cooking time.
- Always cook with lid down to preserve BARBECUE temperature.
- Apply salt only after cooking to prevent drying out the meat.

## BARBECUE COOKING METHODS

**Direct Cooking** — This is the most popular cooking method and involves cooking food directly over the flame, such as searing a steak

**Indirect Cooking** — Food is placed on the cooking grates, offset from the heat source. With the barbecue lid closed reflected heat surrounds the food cooking it more evenly and gently. This method is perfect for roasts, but is also useful whenever you want to slow cook or bake a wide variety of foods. The barbecue lid should always be closed when using the indirect cooking method.

### ⚠ WARNING ⚠

To ensure that it is safe to eat, food must be cooked to the minimum internal temperatures listed in the table below.

AAFC* Safe Minimum Internal Temperatures	
Fish	145° F
Pork	160° F
Egg Dishes	160° F
Steaks and Roasts of Beef, Veal or Lamb	145° F
Ground Beef, Veal or Lamb	160° F
Whole Poultry (Turkey, Chicken, Duck, etc.)	165° F
Ground or Pieces Poultry (Chicken Breast, etc.)	165° F

\* Agriculture and Agri-Food Canada

## APPROXIMATE GRILLING TIMES

BEEF	Size	GRILLING TIME	INTERNAL TEMP
Steaks	3/4" (2cm) thick	3 to 4 min. /side	med rare 145°F (62°C)
		4 to 5 min. /side	med 160°F (71°C)
Kabobs	1" (2.5cm) cubes	3 to 4 min. /side	145°-160°F (62-71°C)
Hamburger patties	1/2" (12mm) thick	3 to 4 min. /side	med 160°F (71°C)
Roast, rolled rump	4-6 lbs. (1.8-2.7kg)	18 to 22 min /lb.	145°-160°F (62-71°C)
Sirloin tip	3 1/2--4 lbs. (1.5-1.8kg)	20 to 25 min. /lb.	145°-160°F (62-71°C)
Ribs, back	cut in 1-rib portions	10 min. /side	med 160°F (71°C)
	half, 2-3 lbs. (0.9-1.3kg)	10 to 12 min. /side	med rare 145°F (62°C)
Tenderloin	whole, 4-6 lbs. (1.8-2.7kg)	12 to 15 min. /side	med 160°F (71°C)
PORK	Size	GRILLING TIME	INTERNAL TEMP
Chops, bone-in	3/4" (2cm) thick	3 to 4 min. /side	med 160°F (71°C)
Chops, bone-out	1 1/2" (4cm) thick	7 to 8 min. /side	med 160°F (71°C)
Tenderloin	1/2-1 1/2 lbs. (0.2-0.6kg)	15 to 25 min. total	med 160°F (71°C)
Ribs (indirect heat)	2-4 lbs. (0.9-1.8kg)	1 1/2 to 2 hrs.	med 160°F (71°C)
VENISON	Size	GRILLING TIME	INTERNAL TEMP
Roast, saddle or leg	6-7 lbs. (2.7-3.1kg)	25 to 30 min. /lb.	145°-160°F (62-71°C)
Steaks	3/4" (2cm) thick	6 to 7 min. /side	med 160°F (71°C)
CHICKEN	Size	GRILLING TIME	INTERNAL TEMP
Broiler fryer (indirect heat)	3-4 lbs. (1.3-1.8kg)	60 to 75 min.	in thigh 180°F (82°C)
Cornish hens	18-24 oz. (510-680g)	45 to 55 min.	in thigh 180°F (82°C)
Breast halves, bone-in	6-8 oz. ( 170-226g) each	10 to 15 min. /side	170°F (77°C)
Breast halves, boneless	4 oz. (113g) each	6 to 8 min. /side	170°F (77°C)
Legs or thighs	4-8 oz. (113-226g)	10 to 15 min. /side	180°F (82°C)
Drumsticks	4 oz. (113g)	8 to 12 min. /side	180°F (82°C)
Wings	2-3 oz. (56-85g)	8 to 12 min. /side	180°F (82°C)

- When outside temperature is cooler than 65°F (18°C) and/or altitude is above 3,500 ft. (1067m), additional cooking time may be required. To insure that meat is completely cooked use a meat thermometer to test internal temperature.
- Lifting grill lid during cooking process may extend cooking time due to heat loss.

## GENERAL SIDE BURNER TIPS (if applicable)

Your side burner will boil, sauté, stir fry and warm with ease.

- For best results preheat your side burner for 10-15 minutes on “HI”
- When boiling water or warming foods always ensure that you are using a covered pot or wok
- Ensure that your gas barbecue is positioned away from high winds or cold air as this will adversely affect your side burner preheating and cooking performance
- Your 11,000-13,000 BTU/hr side burner will take longer to preheat and cook than your indoor range.
- Inspect and clean your side burner orifice periodically and confirm that it is clear of cobwebs or other insect debris that may cause a FLASH FIRE.

## GENERAL SEAR STOVE TIPS (if applicable)

- ALWAYS wear protective gloves when using this high intensity Sear stove.
- ALWAYS keep children, pets and guests away from this Sear stove when in operation.
- The Sear stove lid is for STORAGE ONLY. Only close after stove has cooled down.
- Your Sear stove includes a versatile grate. Always position the accessory needed first, before lighting the Sear stove burner.
- Never place frozen foods on cooking griddle. Always thaw in fridge or at room temperature prior to cooking.
- This Sear stove is temperature adjustable. Only use the “MAX” setting for preheating (only 2 minutes), or for searing foods.
- Avoid overcooking foods by using the temperature setting that best describes the foods you are cooking.
- Due to the intense heat of the Sear stove, food left unattended will burn quickly.
- Avoid Flash-Back Fires by routinely inspecting and cleaning the Sear stove Venturi tube of all debris.
- Avoid water damage and other liquids.
- Do not throw water into the grill to douse a flame or control flare ups.
- Do not attempt to operate the Sear stove in open air while raining.
- When using Sear stove to fry, use a wok topper. Ensure that a lid or splatter screen is used to protect against grease splatter.
- When using Sear stove to sear, always reduce temperatures when desired sear marks have been achieved.

### ATTENTION

**Do not operate the infrared side stove if it appears wet! Remove the burner, turn upside down to drain the excess water, and bring indoors to dry thoroughly.**

## QUICK CHECK™ FUEL GAUGE (if applicable)



Your COLEMAN® EVEN HEAT™ Barbecue comes equipped with the Quick Check™ Fuel Gauge, which helps to remove the guess-work surrounding fuel levels. This easy to read, control panel mounted fuel gauge, will allow the user to quickly check propane levels before, during and after a barbecue session.

The Quick Check™ Fuel Gauge Assembly is made up of three parts, namely; Quick Check™ Fuel gauge, Quick Check™ Hydraulic tube, and the Quick Check™ Tank support bracket. All three parts are factory pre-assembled, and tested to ensure proper function and reliability.

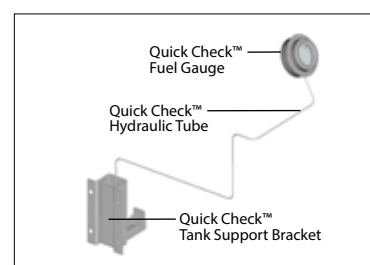

### **CAUTION: To avoid damaging the Quick Check™ Hydraulic systems please pay attention to the following;**

- DO avoid over-bending the hydraulic tube, during assembly.
- Avoid causing leaks in the system by NOT pulling, crimping or bending the Quick Check™ hydraulic tube
- DO avoid excess force at any of the connection points of the Quick Check™ Fuel Gauge Assembly
- DO assemble the Quick Check™ hydraulic tube to the left side panel, to protect and avoid damaging
- DO ensure that ALL HARDWARE is tightened correctly to ensure proper support for the Quick Check™ tank support bracket and tank



## EASY READ 60 MINUTE COOKING TIMER (if applicable)



Your COLEMAN® EVEN HEAT™ Barbecue comes equipped with the easy read 60-minute cooking timer. Times 0 to 60 minutes in 1 minute increments, and sounds with a loud 5-second bell when time expires. This timer is completely mechanical so battery replacement is never needed. To use the timer function on your COLEMAN® EVEN HEAT™ Barbecue, turn the timer knob fully clockwise to enable the alarm, then turn it counter-clockwise to set desired time (in minutes). The timer rings when set time is over.



### Timer

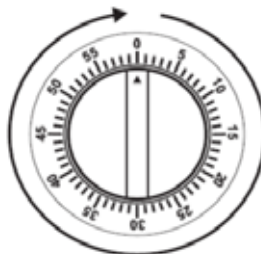

Turn timer knob fully clockwise



Turn timer knob to desired set time

## BATTERY DISPOSAL

Always dispose of used batteries according to local regulation.





# WARNING: HOT SURFACES

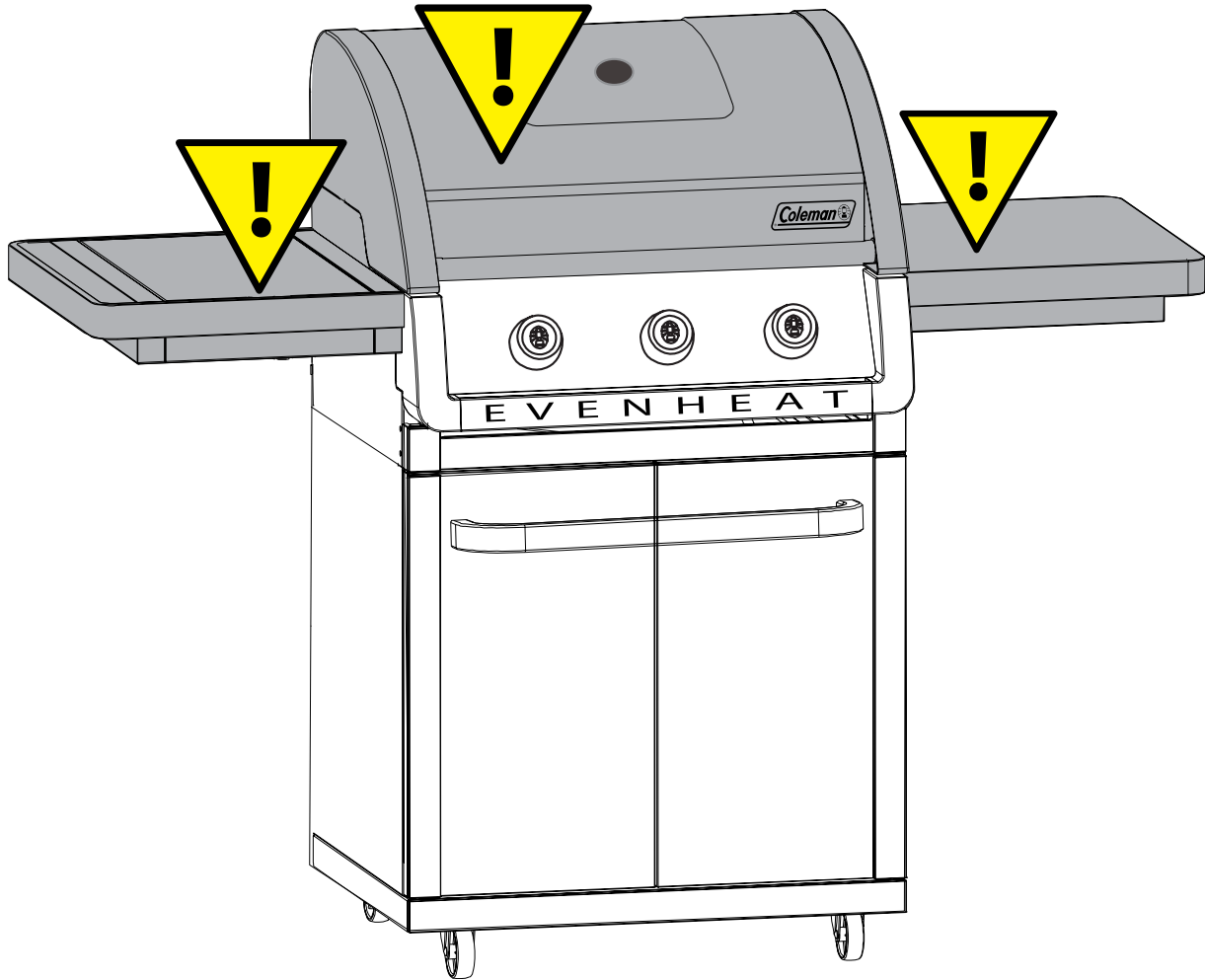

## WARNING

EXTERIOR SURFACES WILL BECOME VERY HOT. TO PREVENT BURNS,  
ALWAYS WEAR INSULATED PROTECTIVE BARBECUE MITTS WHEN  
WORKING AT THE BARBECUE.

- KEEP AWAY FROM COMBUSTIBLE MATERIALS
- KEEP CHILDREN AND PETS AWAY FROM THIS GAS FIRED APPLIANCE
- AVOID DANGEROUS FIRES: DO NOT LEAVE YOUR BBQ UNATTENDED WHILE IN OPERATION

## WARRANTY AND SERVICE

### BEFORE YOU CALL FOR SERVICE have the following information available:

1. **Serial number:** The serial number can be found on the side of the BBQ carton, the cover page of the user manuals, and on the rating label located on the BBQ cart side panel.
2. **Model number:** The model number is located on the front cover of the user manual, the bottom right corner of the rating label and also on your cash register receipt.
3. **Proof of purchase** by the original owner.

Call the Coleman® Customer Care Hotline 1-800-275-4617  
HOURS: 10AM- 7PM EST Mon-Fri, Closed Saturday and Sunday

### IF YOUR PRODUCT IS DAMAGED:

1. Call the Coleman® Customer Care Hotline 1-800-275-4617
2. **Do not return to the store for replacement of damaged or defective parts.** Coleman® Customer Care will ensure that all in-stock replacement parts arrive at your home within 3-10 business days.
3. **Concealed Damage:** If damage is unnoticed until merchandise is unpacked, resolve issue by contacting Coleman® Customer Care immediately. Missing or damaged parts should be claimed within 30 days of purchase.

To ensure your satisfaction and for follow-up service,  
register your BBQ online at [www.colemanbbqs.com](http://www.colemanbbqs.com)

### LIMITED Warranty:

Winners Products, hereby warrants to the ORIGINAL PURCHASER of this Coleman® EVEN HEAT™ Barbecue that it will be free of defects in workmanship, from the date of purchase, for the period of the warranty, as outlined below.

Please see Limitations and Exclusions section on the following page.

Coleman® SMALL SPACES BARBECUE / Coleman® EVEN HEAT™ DUAL FUEL BARBECUE

**Limited Lifetime:**

InstaStart™ Ignition

**Limited 5 Year:**

Stainless Steel EVEN HEAT™ Burners  
Manifold Assembly  
Carryover Bar

**Limited 1 Year:**

All remaining parts

#### CAUTION

Some parts may contain sharp edges – especially as noted in the manual! Wear protective gloves if necessary. **For residential use ONLY. Do not use for commercial cooking.**

#### WARNING

Do not attempt to repair or alter the hose/ valve/ regulator for any assumed defect or for any type of retro fit or conversion. Any modifications to this assembly will void your warranty and create the risk of a gas leak and fire. Use only authorized replacement parts supplied by the manufacturer, for your model.

## LIMITATION AND EXCLUSIONS

Winners Products has the following **limitations** to its warranty:

1. This limited warranty is non-transferable and becomes void if used for commercial or rental purposes.
2. This warranty applies only when barbecue is used in Canada
3. Warranty is in lieu of all warranties, expressed or implied, and all other obligations or liabilities related to the sale or use of its grill products.
4. Winners Products shall not be liable for incidental, consequential, special or contingent damages resulting from its breach of this written warranty or any implied warranty.
5. Winners Products will repair or replace parts, at its option, proven defective under normal use and service and which on examination during the applicable warranty period. (See exclusions to warranty coverage below)
6. Shipping and handling charges are the responsibility of the original consumer-purchaser for all in/out of warranty part orders.
7. This limited warranty will not reimburse you for the cost of any inconvenience, food, personal injury or property damage.
8. Winners Products does not authorize any person or company to assume for it any other obligation or liability in connection with the sale, installation, use, removal, return, or replacement of its equipment; and no such representations are binding on Winners Products.
9. Visit us at [www.colemanbbqs.com](http://www.colemanbbqs.com) to register your product on line. The purchaser shall retain a copy of the purchase invoice for future claims.

**Winners Products excludes from its warranty the following:**

- a. Accidental damage, abuse, tampering or misuse, misapplication, vandalism, careless handling,
- b. Damages caused by improper assembly or installation, alteration, clearance to combustible materials, and failure to follow proper usage, safety and maintenance instructions presented throughout this manual,
- c. Failure to perform regular maintenance, safety checks and service, including but not limited to removal of insects from venturi tubes, resulting in a flash-back fire, damage caused by grease fires, flare-up fires or fires resulting from improper connection of hose to gas source,
- d. Part failure due to lack of cleaning and maintenance, part failure due to use of improper cleaning products, such as indoor stainless steel cleaners, abrasive and chemical cleaners, porcelain oven cleaner and other chemical cleaners which can cause damage to surfaces,
- e. Normal wear and tear, chipping and scratching on painted or porcelain enamel surfaces, dents, discoloration caused by environment or heat, surface corrosion, rust or rust perforation, chemical exposure in the atmosphere and other damages which result with normal use and are otherwise uncontrollable by the manufacturer.

There are no other express warranties except as set forth herein and any applicable implied warranties of merchantability and fitness are limited in duration to the period of coverage of this express written limited warranty.

**To ensure your satisfaction  
And for follow-up service, register your grill online at:  
[www.colemanbbqs.com](http://www.colemanbbqs.com)**

### Join the conversation



[facebook.com/colemangrills](https://facebook.com/colemangrills)



[twitter.com/colemangrills](https://twitter.com/colemangrills)

Coleman®, , and  are registered trademarks of

The Coleman Company, Inc. used under license. ©2016 The Coleman Company, Inc.